

# FIELDPILOT<sup>®</sup>

## USER MANUAL

Assisted Steering Hydraulic Installation Manual for  
Vehicle Kit Number 91-02250 and 91-02290  
Fits Only John Deere 4700



A Subsidiary of  Spraying Systems Co.<sup>®</sup>

## FIELDPILOT®

### Copyrights

© 2010 TeeJet Technologies. All rights reserved. No part of this document or the computer programs described in it may be reproduced, copied, photocopied, translated, or reduced in any form or by any means, electronic or machine readable, recording or otherwise, without prior written consent from TeeJet Technologies.

### Trademarks

Unless otherwise noted, all other brand or product names are trademarks or registered trademarks of their respective companies or organizations.

### Limitation of Liability

TEEJET TECHNOLOGIES PROVIDES THIS MATERIAL "AS IS" WITHOUT WARRANTY OF ANY KIND, EITHER EXPRESSED OR IMPLIED. NO COPYRIGHT LIABILITY OR PATENT IS ASSUMED. IN NO EVENT SHALL TEEJET TECHNOLOGIES BE LIABLE FOR ANY LOSS OF BUSINESS, LOSS OF PROFIT, LOSS OF USE OR DATA, INTERRUPTION OF BUSINESS, OR FOR INDIRECT, SPECIAL, INCIDENTAL, OR CONSEQUENTIAL DAMAGES OF ANY KIND, EVEN IF TEEJET TECHNOLOGIES HAS BEEN ADVISED OF SUCH DAMAGES ARISING FROM TEEJET TECHNOLOGIES SOFTWARE.



## PREPARATION

1. Before beginning the installation, thoroughly clean the vehicle to remove dirt and contaminants that might get into the hydraulic circuit.
2. Park the vehicle on a clean, level floor with adequate clearance to work around.
3. Do not attempt to loosen any hydraulic fittings while the engine is running.
4. Allow the motor and the hydraulics to cool until it is no more than warm to the touch before proceeding.
5. Prior to loosening any hydraulic fittings, be sure to have the appropriate plugs and caps available in order to limit loss of hydraulic fluid from the open fittings.
6. Remove/lower the panels on the underside of the machine to allow access to the hydraulic system.



**PREVENT HYDRAULIC SYSTEM CONTAMINATION.** It is essential to thoroughly clean hydraulic system fittings and hose connections prior to disconnecting or removing them. Use a spray cleaner such as “Brake Clean” to prevent hydraulic system contamination. Note that o-rings used on ORB and ORFF type fittings may be damaged by solvent cleaners such as “Brake Clean”. If a fitting is to be cleaned internally, the o-ring should first be removed and cleaned with a fiberless cloth.

### **IMPORTANT!**

**TO AVOID EXCESS LEAKAGE, DO NOT TURN THE STEERING WHEEL WHILE THE FITTINGS ON THE MANUAL STEERING VALVE ARE DISCONNECTED.**



**WARNING: HOT, HIGH PRESSURE FLUID HAZARD.** Hydraulic oil may be hot and under extreme pressure. To prevent serious injury or death, relieve system pressure and allow the system to cool before repairing or disconnecting. Wear proper hand and eye protection when searching for leaks, using wood or cardboard instead of hands. Keep all hydraulic components in good repair.



**WARNING: PINCH POINT HAZARD!** To prevent serious injury or death, avoid unsafe practice while manually operating hydraulic steering circuits. Keep others away and stay clear of mechanical steering linkages.









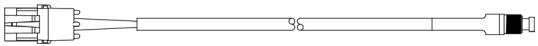

## KIT CONTENTS

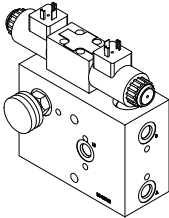
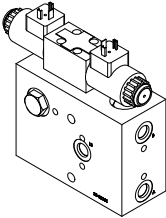
Unpack the installation kit and identify the required parts.

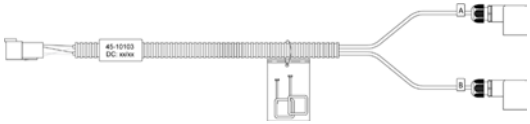
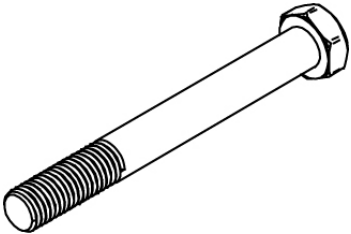
Item	Part Number	Description	Quantity
A	32-04040	Switch, Engage/Disengage.....	1
B	350-0037	Washer, Flat, 3/8" SST.....	3
C*	35-02151	Valve, FieldPilot, CC LS.....	1
C*	35-02180	Valve, FieldPilot, CC LS, PWM.....	1
D	45-07703	Harness, SCM .....	1
E	45-10103	Harness, Valve.....	1
F	60-04087	Bolt, Hex- 3/8-16 x 3-1/4" SST.....	2
G	60-07027	Nut, NyLock 3/8-16, SST .....	2
H	65-05162	Bracket, Hyd. Block Mnt .....	1
I	68-01197	Hose, Hyd. - 1/4" x 100", #6FORF x #4FORF 90EL.....	1
J	68-01198	Hose, Hyd. - 1/4" x 120", #6FORF x #4FORF 90EL.....	1
K	68-01199	Hose, Hyd. - 3/8" x 80", #6FORF x #6FORF 90EL LONG.....	1
L	68-01200	Hose, Hyd. - 3/8" x 182", #6FORF x #6FORF 90EL LONG.....	1
M	68-01201	Hose, Hyd. - 1/4" x 67", #6FORF x #6FORF 90EL.....	1
N	68-02012	Hyd. Load Shuttle - #6FORB.....	1
O	68-02032	Adapter, Hyd. Run Tee - #4 ORF.....	2
P	68-02071	Adapter, Hyd. Run Tee - #6 ORF.....	2
Q	68-02072	Adapter, Hyd. 90 Elbow - #6maleORF x #6femORF .....	1
R	68-02073	Adapter, Hyd. - #6MORF x #6MORB.....	3
S	68-02074	Adapter, Hyd. 90 EL - #6MORF x #6MORB .....	4
T	68-02110	Adapter, Hyd. - #6FORF x #6MORB .....	1
U	90-50013	Cable Tie Kit, 15 .....	1
V	91-07011	Steering Wheel Switch Kit .....	1
W	98-05161	Installation Manual FP, JD 4700 .....	1

\* The valve included depends upon which vehicle kit was ordered.

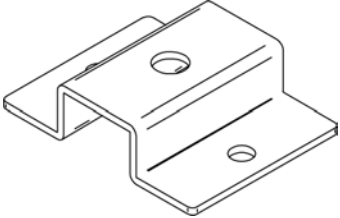
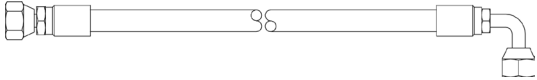
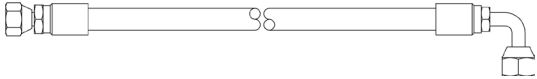
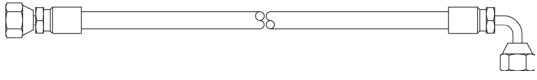
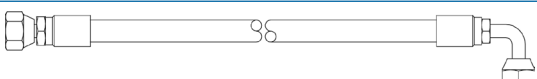
Item	Part #	Description	Illustration
A	32-04040	Switch, Engage/Disengage	
B	350-0037	Washer, Flat, 3/8" SST	
C*	35-02151	Valve, FieldPilot, CC LS	
C*	35-02180	Valve, FieldPilot, CC LS, PWM	
D	45-07703	Harness, SCM	
E	45-10103	Harness, Valve	
F	60-04087	Bolt, Hex- 3/8-16 x 3-1/4" SST	
G	60-07027	Nut, NyLock 3/8-16, SST	

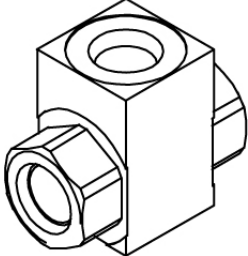
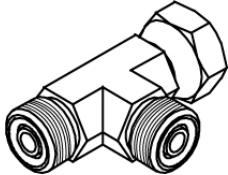
Item	Part #	Description	Illustration
H	65-05162	Bracket, Hyd. Block Mnt	
I	68-01197	Hose, Hyd. - 1/4" x 100", #6FORF x #4FORF 90EL	
J	68-01198	Hose, Hyd. - 1/4" x 120", #6FORF x #4FORF 90EL	
K	68-01199	Hose, Hyd. - 3/8" x 80", #6FORF x #6FORF 90EL LONG	
L	68-01200	Hose, Hyd. - 3/8" x 182", #6FORF x #6FORF 90EL LONG	
M	68-01201	Hose, Hyd. - 1/4" x 67", #6FORF x #6FORF 90EL	
N	68-02012	Hyd. Load Shuttle - #6FORB	
O	68-02032	Adapter, Hyd. Run Tee - #4 ORF	

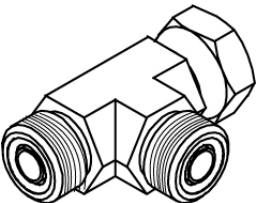
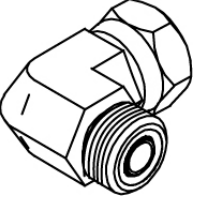
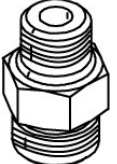
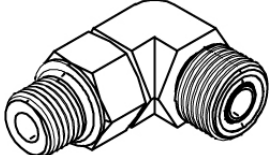
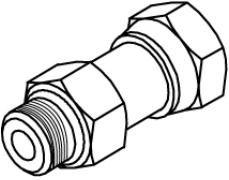
Item	Part #	Description	Illustration
P	68-02071	Adapter, Hyd. Run Tee - #6 ORF	
Q	68-02072	Adapter, Hyd. 90 Elbow - #6maleORF x #6femORF	
R	68-02073	Adapter, Hyd. - #6MORF x #6MORB	
S	68-02074	Adapter, Hyd. 90 EL - #6MORF x #6MORB	
T	68-02110	Adapter, Hyd. - #6FORF x #6MORB	
U	90-50013	Cable Tie Kit, 15	
V	91-07011	Steering Wheel Switch Kit	
W	98-05161	Installation Manual FP, JD 4700	

\* The valve included depends upon which vehicle kit was ordered.

Figure 1-1: Hydraulic Diagram

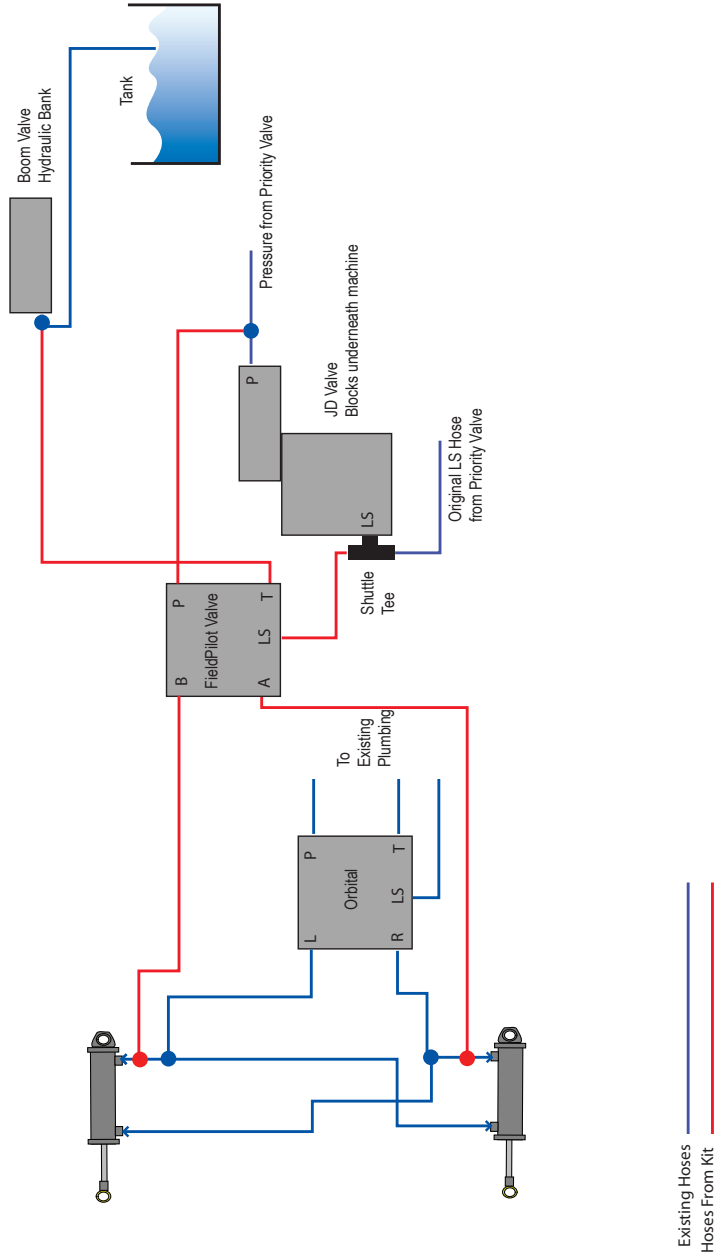



## INSTALLATION



If there are questions concerning the installation of the FieldPilot system on this vehicle, or due to the changes in component specifications the parts supplied in the kit are not exactly as presented in this document, please contact your dealer or TeeJet Customer service representative for clarification before installation. TeeJet Technologies is not responsible for misuse or incorrect installation of the system.

**NOTE: BE VERY CAREFUL TO ABSOLUTELY SECURE ALL CABLES AND HOSES SO THAT THEY DON'T INTERFERE WITH THE MANY MOVING PARTS OF THE MACHINE!**

### 1. PREPARE THE FIELDPILOT VALVE

Make sure the FieldPilot valve (**C**) is clean and free of dust. Work on a clean bench. Remove the plastic plugs and install the elbow adapters (**S**) in the P, T, and A ports. Install the straight adapters (**R**) in the LS and B ports.

Figure 1-2: Preparing FieldPilot Valve

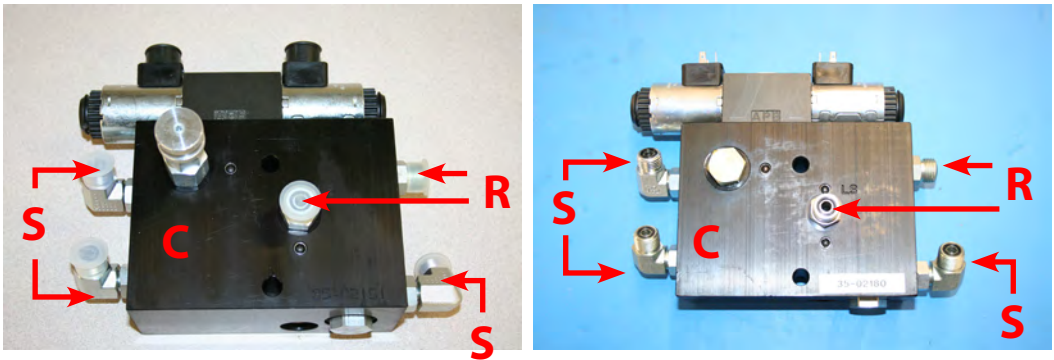

## 2. INSTALL MOUNTING BRACKET

Locate the bolt as illustrated in Figure 1-3 and mount the bracket. The bolt is located under the machine to the left side next to where cables and hoses are run.

*Figure 1-3: Mount the FieldPilot Valve Bracket*

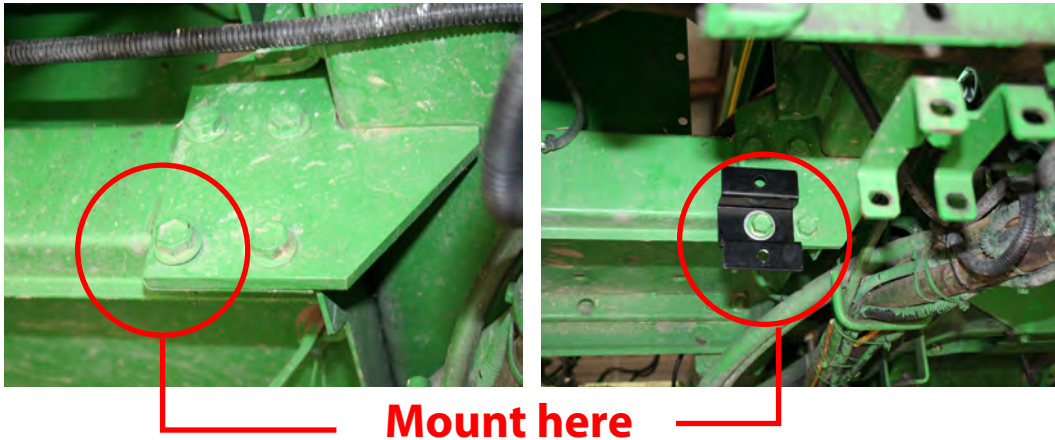

## 3. INSTALL FIELDPILOT VALVE

Using the hardware provided (**B, F, G**) attach the prepared FieldPilot valve to the mounting bracket (**H**) in the orientation shown.

*Figure 1-4: Install FieldPilot Valve*

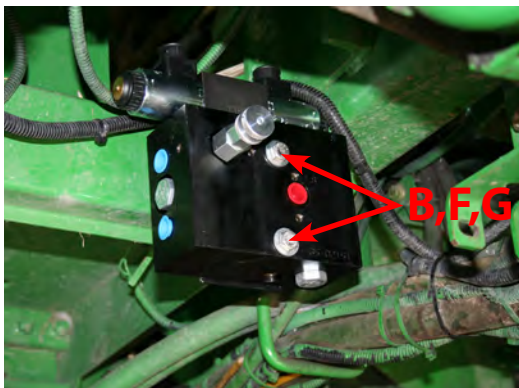

#### 4. INSTALL TANK HOSE AND ADAPTERS

Locate the Tank port on the boom valve bank on the boom. Disconnect the hose at the T port and install run tee (P). Reconnect the original hose to the run of the tee and install adapter (Q) onto the branch of the tee. Connect hose (L) from adapter (Q) and route it along the left side frame to the T port of the FieldPilot valve.

Figure 1-5: Install Tank Hose and Adapters



## 5. INSTALL PRESSURE HOSE AND ADAPTERS

Pressure will come from a valve in the middle underneath the machine. Locate this valve and disconnect the hose as shown. Install the run tee (**P**) and reconnect the original hose to the run of the tee. Connect hose (**K**) from the branch of the tee to the P port of the FieldPilot valve.

Figure 1-6: Install Pressure Hose and Adapters

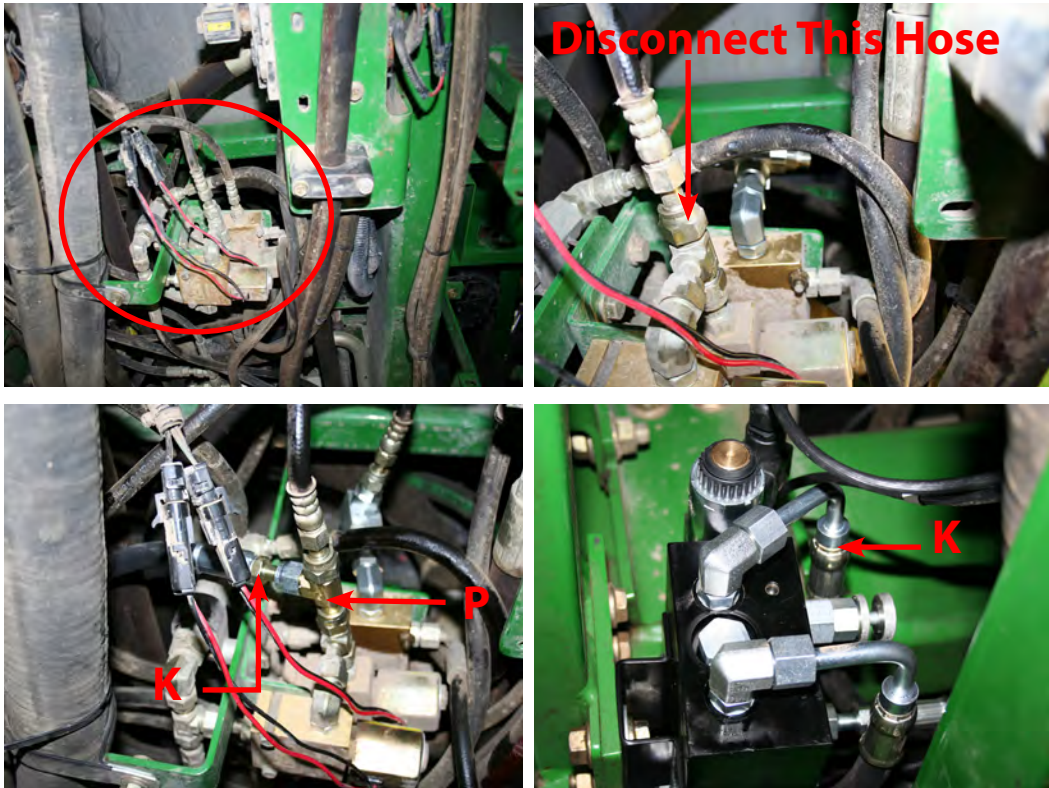

## 6. PREPARE THE SHUTTLE TEE

Install adapters **(R)** and **(T)** in the shuttle tee **(N)**. Just above where the pressure adapter and hose were connected is the LS hose. Disconnect this hose and remove the adapter in the block. Install this adapter in the open port of the shuttle tee **(N)**.

*Figure 1-7: Prepare the Shuttle Tee*

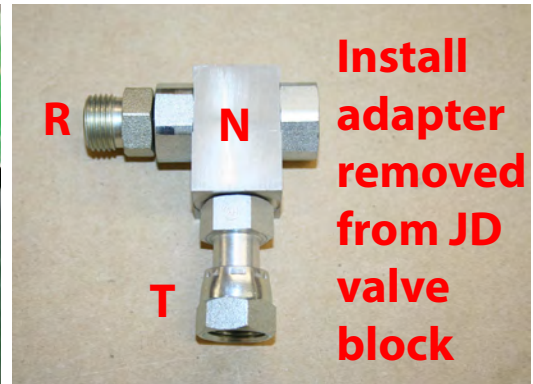
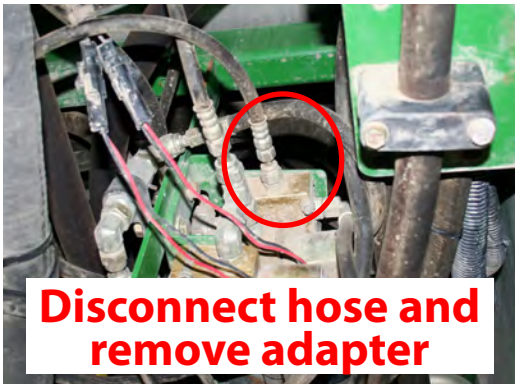

## 7. INSTALL SHUTTLE TEE AND LS HOSE

Install adapter (S) in the open port from Step 6. Connect the shuttle tee (N) to adapter (S) as shown. Connect the original LS hose to the shuttle tee (N). Connect hose (M) from the shuttle tee (N) to the LS port on the FieldPilot Valve.

Figure 1-8: Install Steering Hoses and Adapters

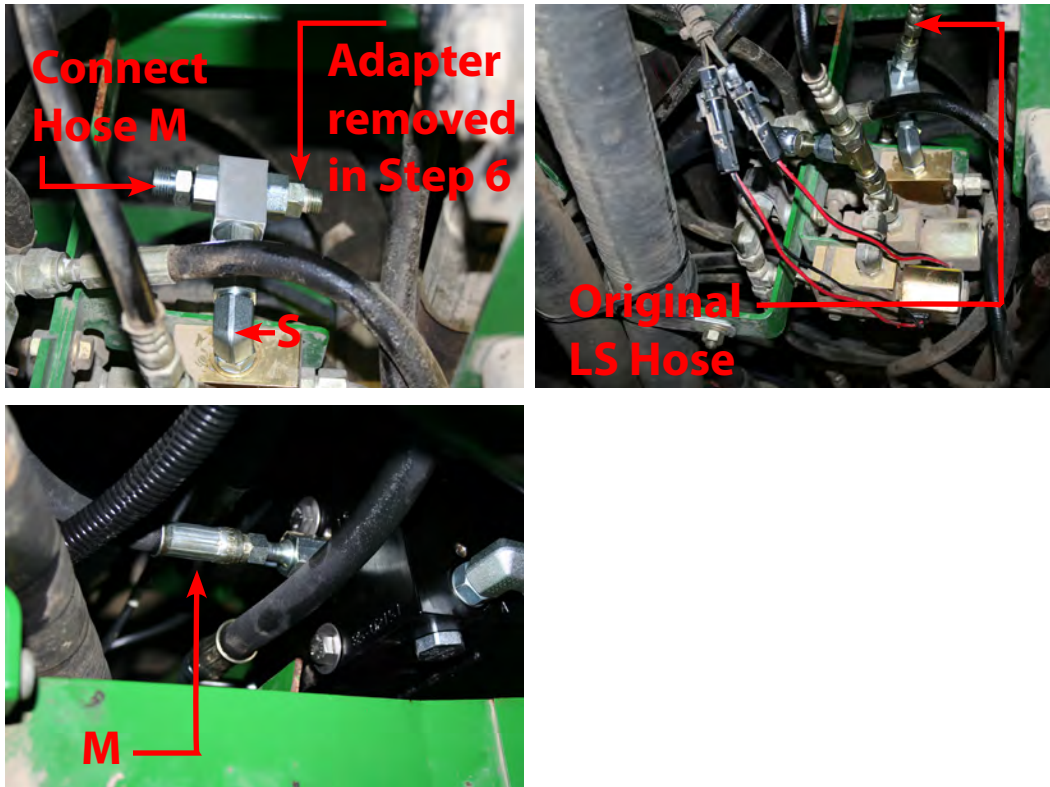

## 8. INSTALL LEFT AND RIGHT STEERING HOSES

The steering hoses will run from the FieldPilot valve to the cylinder on each wheel. Disconnect the line from the left and right cylinders and install run tees (O) as illustrated. Install hose (I) from the A port on the FieldPilot valve to the branch of the run tee on the cylinder of the left wheel. Install hose (J) from the B port on the FieldPilot valve to the branch of the run tee on the cylinder of the right wheel.

Figure 1-9: Install Left and Right Steering Hoses

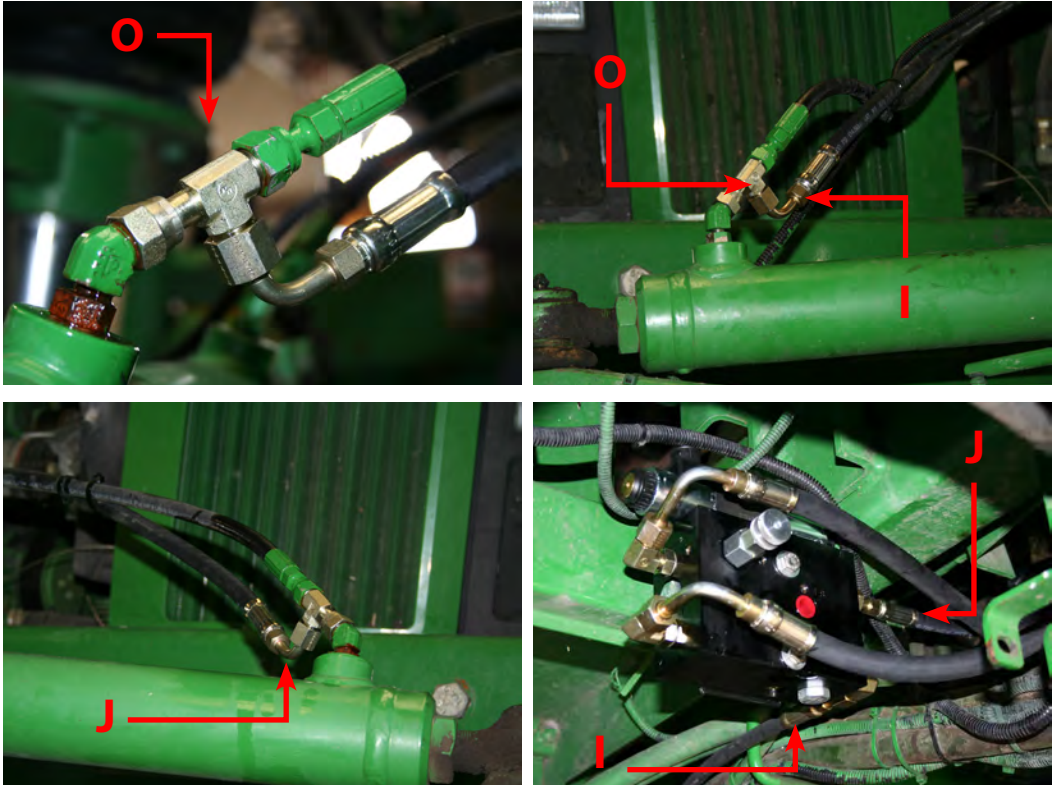

## 9. INSTALL STEERING DISENGAGE SENSOR

Remove the shields around the steering column in the cab. Mount the bracket from kit (V) as shown. Glue magnets to the steering shaft (the magnets will need to be cut in half because the shaft is small). Install the sensor in the bracket. Set the clearance between the magnet and the sensor as close to  $\frac{1}{8}$ " as possible.

Figure 1-10: Install Steering Disengage Sensor

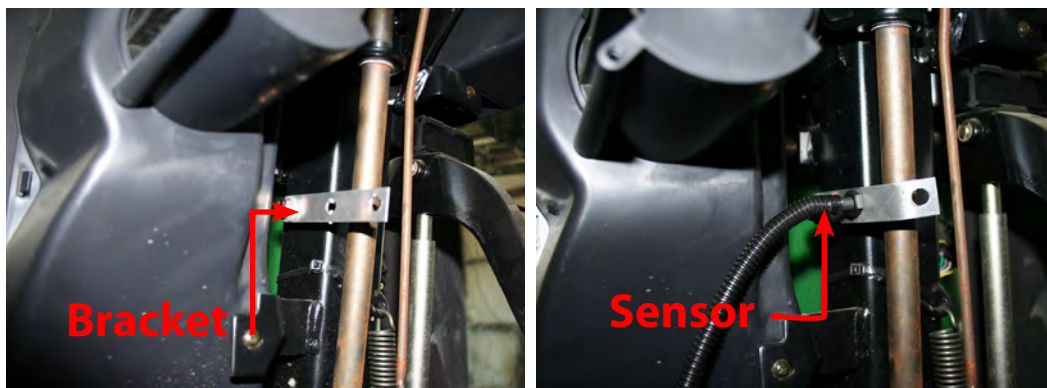

## 10. INSTALL STEERING ENGAGE/DISENGAGE SWITCH

Connect item (A) to the connector on the SCM harness labeled Remote Engage/Disengage. Install the push button switch in a location that is easily accessible during operation of the machine. Optional foot switch 32-04020 can be used in place of switch (A) if desired.

Figure 1-11: Install Steering Engage/Disengage Switch



## 11. RECOMMENDED ELECTRONICS INSTALLATION

The Steering Control Module (SCM) should be securely mounted as level as possible to the floor. It must be mounted with the arrows pointing toward the direction of travel. The control console can be mounted to the preference of the operator. The GPS antenna should be mounted as far forward as possible on the cab on a metal surface of at least 4" square.

*Figure 1-12: Recommended Electronics Installation*

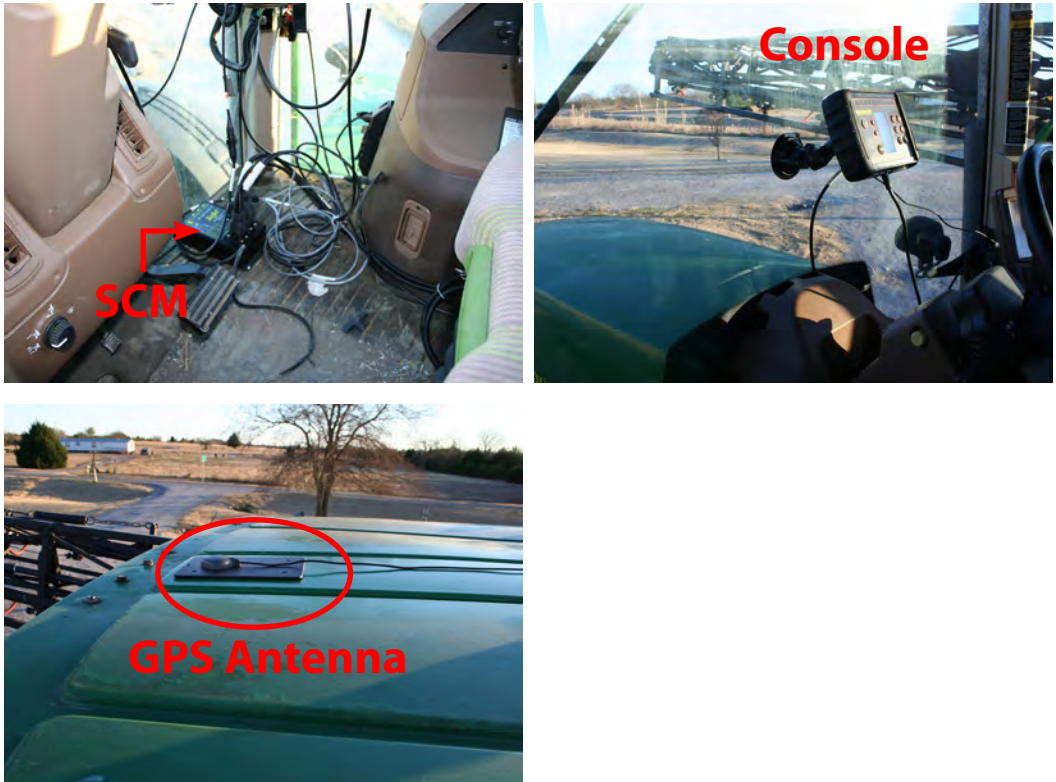

## 12. VERIFY OPERATION OF HYDRAULICS AND SET THE STEERING CONTROL RATE

Clean and pick up the area around the vehicle and make certain that it is safe to operate. Start the engine and check hydraulic connections for leaks. Rotate the steering wheel from one extreme to the other and back to center, check for leaks. While steering through the extremes of movement, check the cables and hoses for wear points and strain, adjust as necessary.

**If using a Matrix series console and PWM control, then the oil flow rate adjustment is accomplished through the console. The target lock to lock time is 6 seconds. Refer to the Matrix manual for further instructions.**

If using a CL220 or CL230 console then refer to the following instructions for adjusting the oil flow rate.

**Adjust the hydraulic oil flow control knob on the FieldPilot valve to a starting position of 3½ turns from completely closed.** Adjust the oil flow by turning the knob clockwise to reduce flow (increase seconds) and counter-clockwise to increase flow (decrease seconds).

Use the electronic steering control console to perform the left to right steering test, counting the seconds to move the wheels from full left to full right and also in the opposite direction. It is a good idea to have the vehicle moving forward very slowly during these tests so there is not excessive side pressure on the tires. If you find that the machine steers in the opposite direction from that being commanded in this steering test sequence, switch the valve connectors at the FieldPilot valve coils.

Do this a number of times, adjusting the oil flow between tests, until a lock to lock steering response of approximately **18 seconds** is observed using a CenterLine® 220. Adjust to **14 seconds** when using a CenterLine® 230BP. Use the locking nut to secure this flow setting. The coils on the FieldPilot valve also have manual push button overrides.

*NOTE: To activate the manual overrides, a tool such as a small screwdriver or allen wrench must be inserted into the end of the coil to depress the override button.*



**WARNING: PINCH POINT HAZARD!** To prevent serious injury or death, avoid unsafe practice while manually operating hydraulic steering circuits. Keep others away and stay clear of mechanical steering linkages.

## 13. COMPLETE ELECTRONIC INSTALLATION

Refer to the owner's manual supplied with the automated steering system to complete the electronic installation and setup.

# FIELDPILOT®

## USER MANUAL

---

A series of equipment-specific hydraulic installation kits have been developed to work in conjunction with your assisted steering system. This kit contains the necessary components and instructions to install assisted steering hydraulics on the John Deere 4700. Please review this manual thoroughly before beginning the installation process.



1801 Business Park Drive  
Springfield, Illinois 62703 USA  
Tel: (217) 753-8424 • Fax: (217) 753-8426  
[www.teejet.com](http://www.teejet.com)

A Subsidiary of  *Spraying Systems Co.*®

98-05161 R1  
© TeeJet Technologies 2010