

FIELDWARE for SMARTPAD II Quick Start Guide

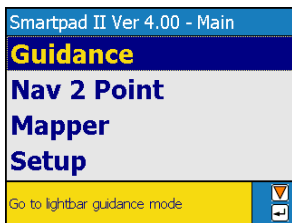

COMPACTFLASH CARD 256MB

SCREEN SELECTION



TOUCH SCREEN SELECTION

To make a selection use a stylus and single tap the screen on the desired menu.

MANUAL SELECTION

Items can only be selected when highlighted. Use the Up and Down arrows (▲▼) to highlight the desired selection. Press Enter (↵) to select.

DATA ENTRY



ON-SCREEN KEYBOARD ENTRY

Select the desired menu to be changed. Select the Keyboard icon (⌨) to bring up the on screen keyboard. This icon will appear in the upper left corner of the screen only when text can be entered. Select the desired character using a stylus and press Enter (↵) to accept.

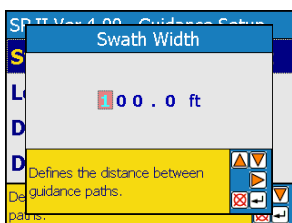

MANUAL ENTRY

Select the desired menu to be changed, and use the Up and Down arrows (▲▼) to change the character. Use the Left and Right arrows (◀▶) to advance to the next character. Press Enter (↵) to accept.

INSTALLATION GUIDE

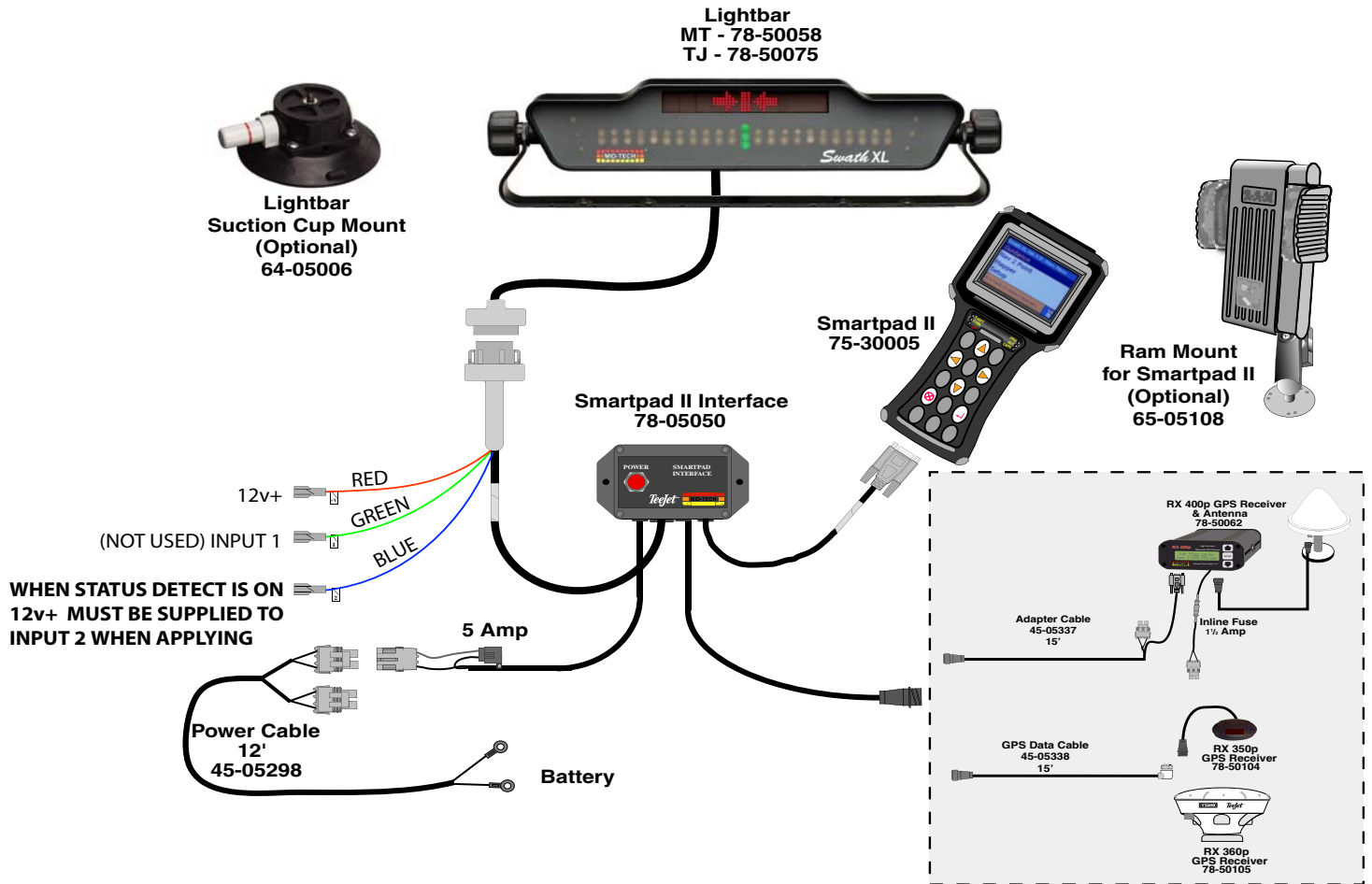

INSTALLATION INSTRUCTIONS

1. The Lightbar can be mounted inside or outside the cab. The lightbar is weather proof but not resistant to high water pressures.
2. The GPS antenna must be mounted with a clear view of the sky. The tallest point on the vehicle is preferred. When using a 2-way radio the GPS antenna and cables should be mounted as far away as possible from the 2-way antenna and cables.
3. Midwest Technologies recommends that the power source come directly from the battery.
4. When using an existing switch in the cab to signal to the SmartPad that the application has begun, two things must be done.
 - A. On the SmartPad under the guidance setup menu locate Status Detect **Status Detect** - This must be set to **1 Section**. See Page 5 of this bulletin.
 - B. See diagram above. When Status Detect is set to 1 Section 12v+ must be supplied to Input 2 when applying. Connect Input 2 (Blue Wire) to the switched 12v+ side of the master switch when the implement is applying.

WHAT'S NEW WITH SMARTPAD II

Bulletin 98-01122

R3

General

- Touch screen
- Uses Compact Flash storage cards
- Uses existing Swath XL and Guideline interface and lightbar
- Software now called "Fieldware for the Smart Pad II"
- Pop up keyboard for touch screen entry of names and values
- View and delete files from card
- Adjust brightness and backlight with keys on keypad
- Added "Pan" feature allowing users to move around and zoom in on the map in real time with key strokes
- Touching objects in real time brings up the object's info
- E-Dif ready
- Added a "GPS Logger" application under Tools to log raw GGA output from a receiver

Nav-2-Point

- View GMF files as background
- Show BND files as background
- Last visited sample point is "remembered" eliminating need to scroll to next sample number

Guidance

- As Applied data can now be viewed in Solid view or Boom Pattern view
- Curved AB now a guidance type
- Guidance Type now selected in real time menu
- Distance to next pass information displayed on lightbar
- Verification before creating a new guideline when one already exists
- Can now collect where-applied data without lightbar connected
- Last guidance type selected now remembered on exit and for next job
- GPS Type and GPS Data Rate are now selectable during setup
- Antenna Height for tilt sensor option

Mapper

- Mapper now added as an application
- Allows mapping of points, hazards, lines, polygons and boundaries

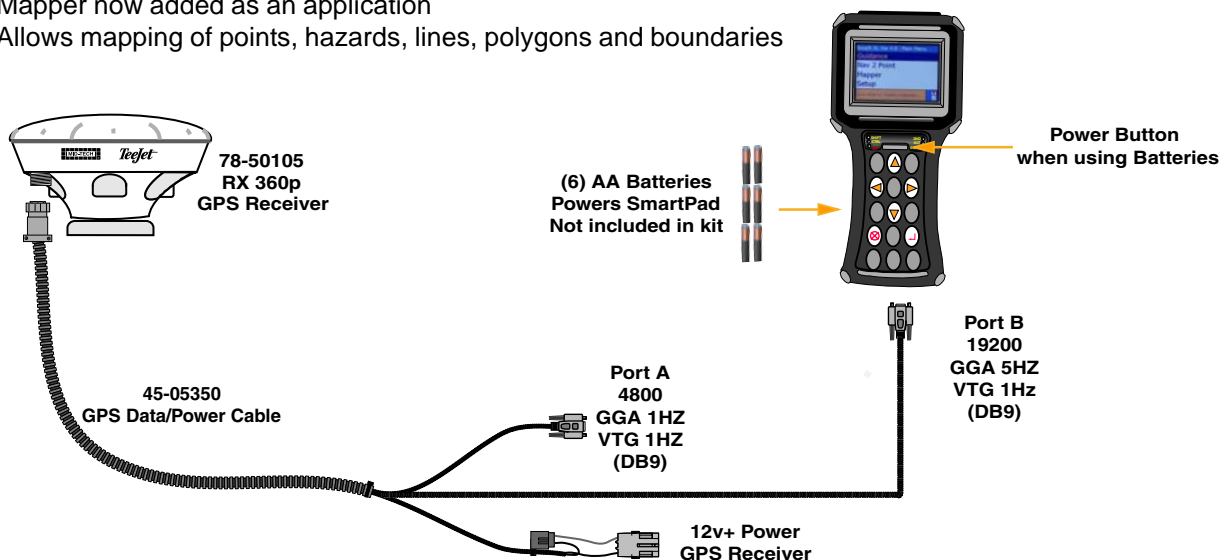

The illustration above shows one of the new features of the SmartPad II. This configuration makes the system very mobile and easy to transfer for off-season mapping opportunities including field boundaries, tile lines, hazards, and many other items that may fit your application. It is not necessary to use the smartpad interface or the lightbar with the mapper application. The SmartPad II can be powered using six AA batteries and the only power needed is 12v+ to the receiver.

GETTING STARTED

MAIN LAUNCHER

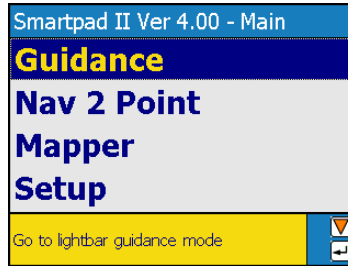

The Main Launcher is the first menu page you see after powering up the SmartPad II. This is the top menu page and from here you can launch an application. The Fieldware for SmartPad II software is made up of three software applications (programs), Guidance, Nav2Point, and Mapper. Each application can be broken down into two main components, Setup and Real-Time Mapping. Use the next few pages to see the Setup structure and Real-time buttons for the application you choose to use. Review all setup settings and make changes as needed. Remember to use the on screen help window to determine what data should be entered.

Example: Entering the Swath Width in the Guidance application: See page 5 (this is the flow chart for the guidance application) follow the chart to Swath Width. Notice that **Guidance** is selected from the main launcher screen, then select **Setup**, and the final step would be to select **Guidance**. From this point **Swath Width** is one of items that should be setup before starting guidance. This procedure is the same for all three applications (Guidance, Nav2Point, and Mapper) each application has its own flow chart.

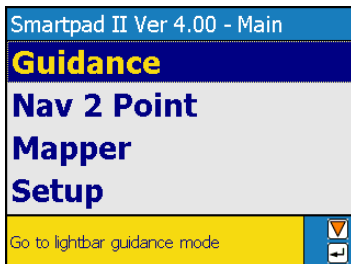

The Guidance application provides the operator with clear and intuitive steering assistance as well as real-time application information. The operator can select between four different guidance modes:

Parallel



Curved



Curved A-B



Center Pivot

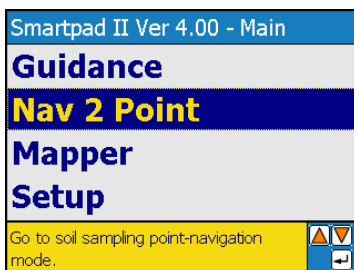

The Nav2Point application allows you to navigate to specific predetermined point locations, or to more generalized areas of a field, based on various types of background data such as yield or soil maps. Once at the desired location, add that location as a sample point and assign a point number and location name. The primary use of the Nav2Point application will be for soil sampling.

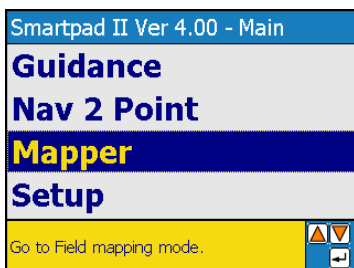

The Mapper application allows the operator to map field boundaries, weed patches, insect infestation, ponds, water ways, rocks, tile lines, as well as many other features you feel are important to your operation. Features can be mapped as points, lines, or polygons.

GUIDANCE SETUP

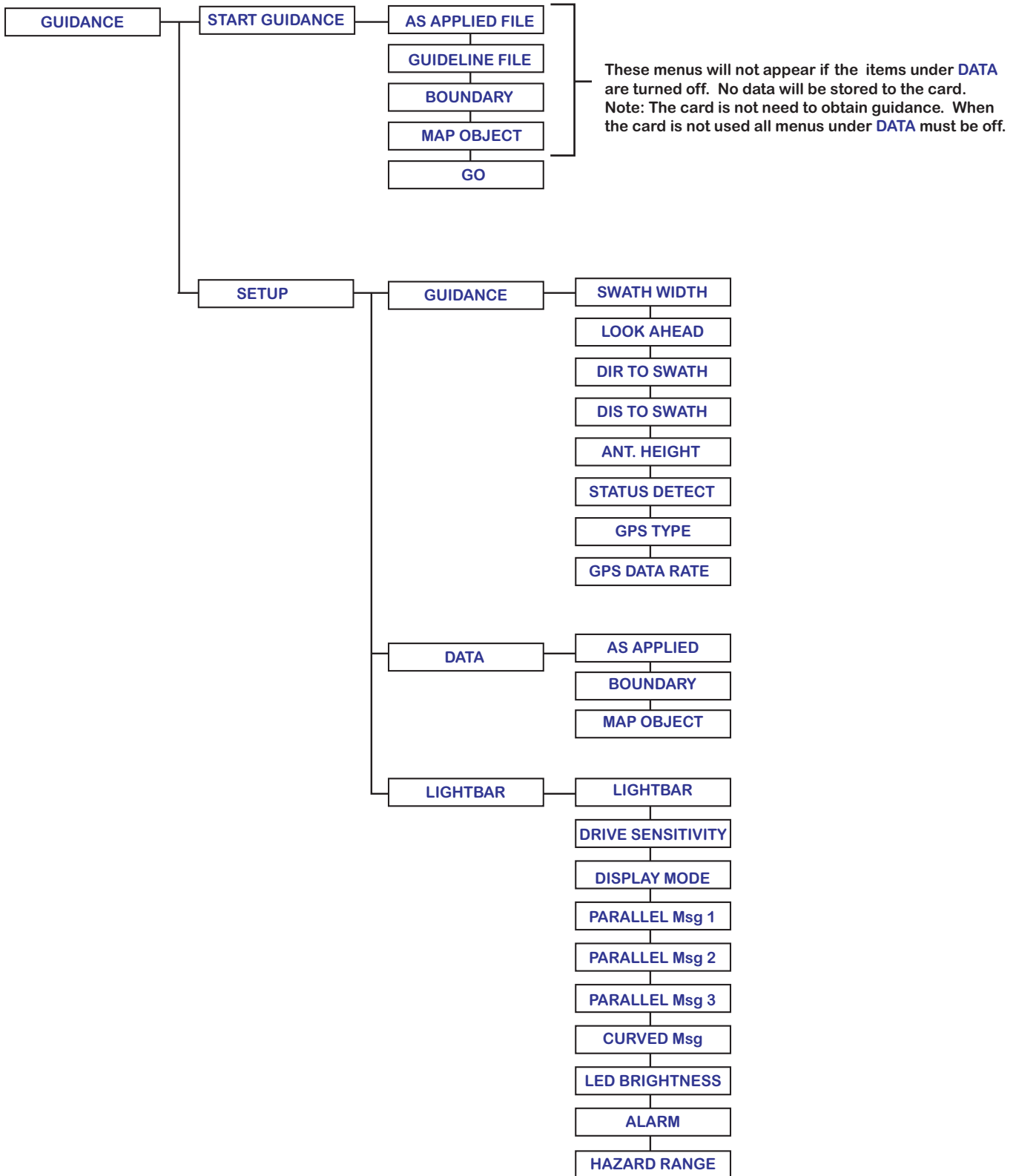







































These menus will not appear if the items under **DATA** are turned off. No data will be stored to the card.
 Note: The card is not needed to obtain guidance. When the card is not used all menus under **DATA** must be off.

! USE THE ON BOARD HELP MENU FOR INSTRUCTIONS OR DESCRIPTION OF ITEM SELECTED !

SP II Ver 4.00 - Lightbar Setup	
Drive Sensitivity	1.5ft
Display Mode	Swath
Parallel Msg 1	X-Track
Parallel Msg 2	Swath #
Defines how guidance information is visually conveyed to the user.	

REAL-TIME GUIDANCE BUTTONS

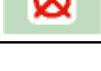
REAL-TIME GUIDANCE DEFAULT BUTTONS		REAL-TIME GUIDANCE PATTERNS	
	Mark A - This button is used with Parallel and Curved A-B guidance. This button is pressed to mark the first end point of the initial guideline.		Parallel Straight A-B - This button indicates the current guidance pattern in Parallel. Pressing this button will bring up the other guidance mode buttons as shown in this section.
	Mark B - This button is used with Parallel and Curved A-B guidance. This button is pressed to mark the end point of the initial guideline.		Curved - This button indicates the current guidance pattern in Curved. Pressing this button will bring up the other guidance mode buttons as shown in this section.
	New Guideline - This button will appear after the initial guideline has been created. When pressed this SamartPad II will ask for a new guideline, if accepted Mark A button will appear.		Circle Pivot - This button indicates the current guidance pattern in Circle Pivot. Pressing this button will bring up the other guidance mode buttons as shown in this section.
	Mark A Circle Pivot - This button is pressed to mark the first end point of the initial circle guideline.		Curved A-B - This button indicates the current guidance pattern in Curved A-B. Pressing this button will bring up the other guidance mode buttons as shown in this section.
	Mark B Circle Pivot - This button is pressed to mark the end point of the initial circle guideline.	REAL-TIME ZOOM AND PAN	
	Mark B Circle Pivot Wait - This button appears when the Mark A Circle Pivot has been pressed and the software is collecting enough points (approximately 12 seconds) to describe a circle. After this time period the Mark B Circle Pivot button will appear.		
	Zoom In - When pressed this button decreases area displayed in the view page. There are a total of 5 zoom levels.		Zoom Pan Mode - When pressed this button will enter into Pan mode. The buttons below will appear and can be used to pan the screen Up, Down, Left, and Right.
	Zoom Out - When pressed this button increases area displayed in the view page. There are a total of 5 zoom levels.		Pan Up - When pressed this button will scroll to the collected data at the Top of the screen
	Applied Swath Off - When this button is displayed, the spray or spreader is Off. When pressed this button changes to Applied Status On button.		Pan Down - When pressed this button will scroll to the collected data at the Bottom of the screen
	Applied Swath ON - When this button is displayed, the spray or spreader is On. When pressed this button changes to Applied Status Off button. Note: When using Status Detect this button will change automatically.		Pan Left - When pressed this button will scroll to the collected data on the Left side of the screen
	Map Field Boundary Off - When this button is displayed, the field boundary is not being mapped. When pressed this button changes to the Map Field Boundary On Button.		Pan Right - When pressed this button will scroll to the collected data on the Right side of the screen
	Map Field Boundary ON - When this button is displayed, the field boundary is being mapped. When pressed this button changes to the Map Field Boundary Off Button.		Snap - When pressed the screen will zoom out to its fullest extent allowing view of the entire working area.
	Mark Point - This is the point map object button. When pressed, a point is placed at the vehicle location. This button is a result of the Data Setup - Map Object menu item.		Zoom In - When pressed this button decreases area displayed in the view page. There are a total of 5 zoom levels.
	Mark Hazard - This is the hazard map object button. When pressed, a hazard placed at the vehicle location. This button is a result of the Data Setup - Map Object menu item.		Zoom Out - When pressed this button increases area displayed in the view page. There are a total of 5 zoom levels.
	Full Screen - When Pressed, the entire view page space is replaced by the map window. This is useful to see more of the vehicle trajectory. Press exit  to return to the normal view page.		Exit Pan Mode - When pressed Pan Mode is exited and the Zoom Pan Mode button will be highlighted.
		REAL-TIME OPTIONS MENU	
	Information - When this button is highlighted, information is displayed in the information window and on the screen.		Option Menu - When pressed, the real-time display options are displayed. The options are listed below.
	Locked Information - When this button is displayed, it mean that the Information Button was pressed. Information stays displayed in the Information Window while moving to other buttons in the button bar.		North Up View - This display option keeps North pointing to the top of the view page. When pressed, this button changes to the COG View button.
	Exit - When pressed, the software exits out of real-time process and returns to the Start Guidance page. Pressing the  key automatically highlights this button.		Course on Ground (COG) View - This display option keeps the vehicle stationary in the view page with the heading (course) of the vehicle pointing to the top of the view page. When pressed, this button changes to the North Up View button.
			Boom Applied View - This drops bars representing the boom where applied. This view can help show overlap. When pressed, this button changes to the Solid Applied View button.
			Solid Applied View - This colors a solid path of where applied. This view can help show skips. When pressed, this button changes to the Boom Applied View button.
			Exit Options Menu - When pressed the Option Menu is exited and the Option Menu button will be highlighted.



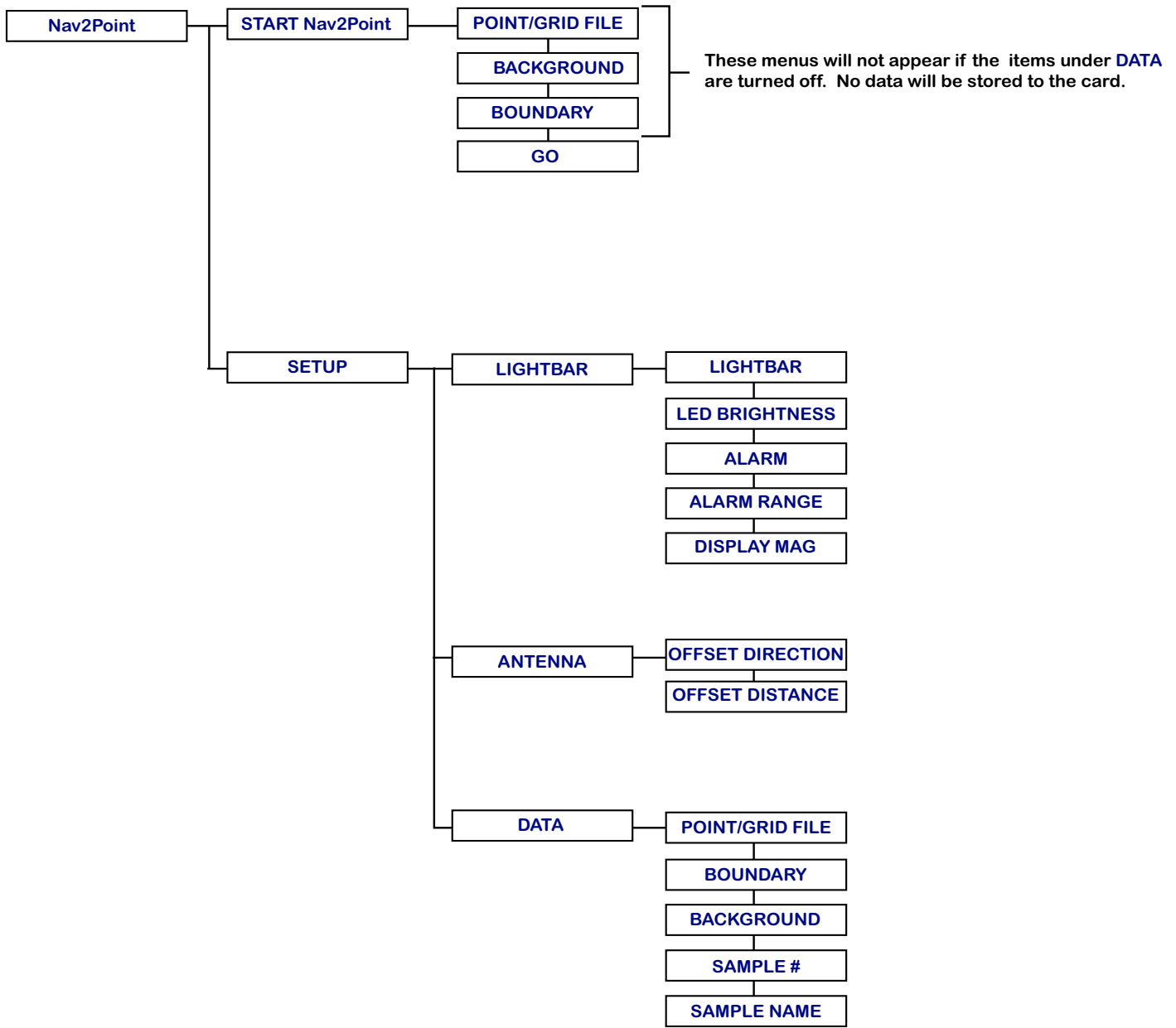



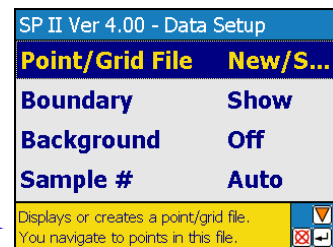



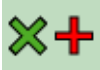

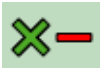









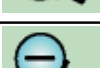



Nav2Point SETUP



! USE THE ON BOARD HELP MENU FOR INSTRUCTIONS OR DESCRIPTION OF ITEM SELECTED **!**

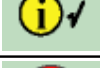
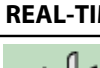

REAL-TIME Nav2Point BUTTONS

REAL-TIME Nav2Point DEFAULT BUTTONS		REAL-TIME ZOOM AND PAN	
	Add Sample - When pressed a sample point is dropped at the antenna offset position. The user is prompted for sample number and name, depending on how Data Setup is configured.		Zoom Pan Mode - When pressed this button will enter into Pan mode. The buttons below will appear and can be used to pan the screen Up, Down, Left, and Right.
	Delete Sample - The user must be over (very close to) an existing sample point. Once pressed the sample point is removed from the view and data file.		Pan Up - When pressed this button will scroll to the collected data at the Top of the screen.
	Start Navigation - Press this button to select and navigate to an existing point. Once pressed this button changes to Stop Navigation button.		Pan Down - When pressed this button will scroll to the collected data at the Bottom of the screen.
	Stop Navigation - This button appears when the Start Navigation button has been pressed. Once pressed, the current navigation to an existing point is stopped and this button changes back to the Start Navigation button.		Pan Left - When pressed this button will scroll to the collected data on the Left side of the screen.
	Edit Sample - The user must be over (very close to) an existing sample point. Once pressed, a dialog containing the sample number and name appears. The user is able to edit these two sample point attributes.		Pan Right - When pressed this button will scroll to the collected data on the Right side of the screen.
	Zoom In - When pressed this button decreases area displayed in the view page. There are a total of 5 zoom levels.		Snap - When pressed the screen will zoom out to its fullest extent allowing view of the entire working area.
	Zoom Out - When pressed this button increases area displayed in the view page. There are a total of 5 zoom levels.		Zoom In - When pressed this button decreases area displayed in the view page. There are a total of 5 zoom levels.
	Map Field Boundary Off - When this button is displayed, the field boundary is not being mapped. When pressed this button changes to the Map Field Boundary On Button.		Zoom Out - When pressed this button increases area displayed in the view page. There are a total of 5 zoom levels.
	Map Field Boundary ON - When this button is displayed, the field boundary is being mapped. When pressed this button changes to the Map Field Boundary Off Button.		Exit Pan Mode - When pressed Pan Mode is exited and the Zoom Pan Mode button will be highlighted.
	Mark Point - This is the point map object button. When pressed, a point is placed at the vehicle location. This button is a result of the Data Setup - Map Object menu item.		
	Mark Hazard - This is the hazard map object button. When pressed, a hazard is placed at the vehicle location. This button is a result of the Data Setup - Map Object menu item.		
	Full Screen - When Pressed, the entire view page space is replaced by the map window. This is useful to see more of the vehicle trajectory. Press exit (⊠) to return to the normal view page.		
	Information - When this button is highlighted, information is displayed in the information window and on the screen.		
	Locked Information - When this button is displayed, it means that the Information Button was pressed. Information stays displayed in the Information Window while moving to other buttons in the button bar.		
	Exit - When pressed, the software exits out of real-time process and returns to the Start Guidance page. Pressing the (⊠) key automatically highlights this button.		
REAL-TIME OPTIONS MENU			
	Option Menu - When pressed, the real-time display options are displayed. The options are listed below.		
	North Up View - This display option keeps North pointing to the top of the view page. When pressed, this button changes to the COG View button.		
	Course on Ground (COG) View - This display option keeps the vehicle stationary in the view page with the heading (course) of the vehicle pointing to the top of the view page. When pressed, this button changes to the North Up View button.		
	Exit Options Menu - When pressed the Option Menu is exited and the Option Menu button will be highlighted.		



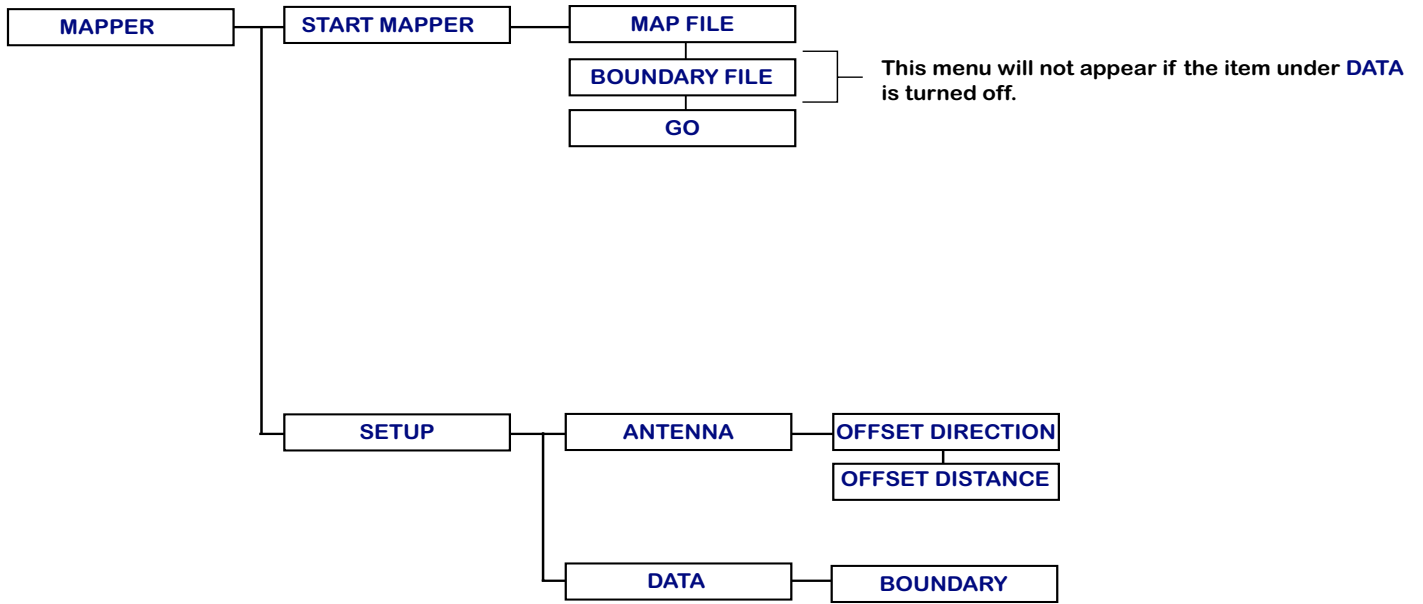



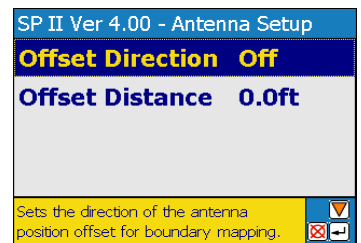























MAPPER SETUP







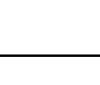
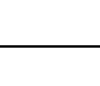





! USE THE ON BOARD HELP MENU FOR INSTRUCTIONS OR DESCRIPTION OF ITEM SELECTED !











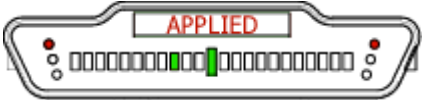

REAL-TIME MAPPER BUTTONS

REAL-TIME MAP OBJECT BUTTONS		REAL-TIME ZOOM AND PAN	
	Polygon Mark - Used to map or locate features that can be represented by a closed shape made of discrete points. When pressed the Map Object buttons change to Mark Polygon Point button. Press to mark a point along the polygon perimeter. When finished press the Finish Flag button.		Zoom Pan Mode - When pressed this button will enter into Pan mode. The buttons below will appear and can be used to pan the screen Up, Down, Left, and Right.
	Polygon Stream - Used to map or locate features that can be represented by a closed shape made up of streaming points. When pressed the Map Object buttons changes to the Finish Flag button. Press the Finish Flag to close the polygon.		Pan Up - When pressed this button will scroll to the collected data at the Top of the screen.
	Polyline Mark - Used to map or locate features that can be represented by a line of discrete points. When pressed the Map Object buttons change to Mark Polyline Point button. Press to mark a point along the polyline. When finished press the Finish Flag button.		Pan Down - When pressed this button will scroll to the collected data at the Bottom of the screen.
	Polyline Stream - Used to map or locate features that can be represented by a line of streaming points. When pressed the Map Object buttons changes to the Finish Flag button. Press the the Finish Flag to close the polygon.		Pan Left - When pressed this button will scroll to the collected data on the Left side of the screen.
	Mark Polygon/Polyline Point - Used to mark points only when Polygon Mark or Polyline Mark button is selected. This button goes away after the Finish Flag button is selected.		Pan Right - When pressed this button will scroll to the collected data on the Right side of the screen.
	Finish Flag - Used to exit out or close Map Object operations. When pressed all Map Object buttons appear.		Snap - When pressed the screen will zoom out to its fullest extent allowing view of the entire working area.
REAL-TIME MAPPER DEFAULT BUTTONS			Zoom In - When pressed this button decreases area displayed in the view page. There are a total of 5 zoom levels.
	Mark Point - This is the point map object button. When pressed, a point is placed at the vehicle location. This button is a result of the Data Setup - Map Object menu item.		Zoom Out - When pressed this button increases area displayed in the view page. There are a total of 5 zoom levels.
	Zoom In - When pressed this button decreases area displayed in the view page. There are a total of 5 zoom levels.		Exit Pan Mode - When pressed Pan Mode is exited and the Zoom Pan Mode button will be highlighted.
	Zoom Out - When pressed this button increases area displayed in the view page. There are a total of 5 zoom levels.	REAL-TIME OPTIONS MENU	
	Map Field Boundary Off - When this button is displayed, the field boundary is not being mapped. When pressed this button changes to the Map Field Boundary On Button.		Option Menu - When pressed, the real-time display options are displayed. The options are listed below.
	Map Field Boundary ON - When this button is displayed, the field boundary is being mapped. When pressed this button changes to the Map Field Boundary Off Button.		North Up View - This display option keeps North pointing to the top of the view page. When pressed, this button changes to the COG View button.
	Mark Hazard - This is the hazard map object button. When pressed, a hazard placed at the vehicle location. This button is a result of the Data Setup - Map Object menu item.		Course on Ground (COG) View - This display option keeps the vehicle stationary in the view page with the heading (course) of the vehicle pointing to the top of the view page. When pressed, this button changes to the North Up View button.
	Full Screen - When Pressed, the entire view page space is replaced by the map window. This is useful to see more of the vehicle trajectory. Press exit  to return to the normal view page.		Exit Options Menu - When pressed the Option Menu is exited and the Option Menu button will be highlighted.
	Information - When this button is highlighted, information is displayed in the information window and on the screen.		
	Locked Information - When this button is displayed, it mean that the Information Button was pressed. Information stays displayed in the Information Window while moving to other buttons in the button bar.		
	Exit - When pressed, the software exits out of real-time process and returns to the Start Guidance page. Pressing the  key automatically highlights this button.		

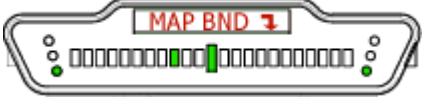
LIGHTBAR INDEX

LIGHTBAR STATE	DESCRIPTION
	<p>Mark A: Displayed when establishing the guidance point A of the initial guideline.</p>
	<p>Mark B: Displayed when establishing the guidance point B of the initial guideline.</p>
	<p>Swath #: A user selected lightbar message. When not on the initial guideline the first character is either L or R for Left and Right of the initial guideline. The number identifies how many lines left or right of the initial guideline.</p>
	<p>X-Track Error: A user defined lightbar message. This cross track error message is displayed when the vehicle is on the guideline and there is no error.</p>
	<p>X-Track Error: A user defined lightbar message. In this example the operator should steer to the left 2.3ft. (Assuming the system unit is set to US and lightbar is set to Swath mode.)</p>
	<p>Vehicle Heading Error: A user defined lightbar message indicating the current heading error between vehicle heading and the bearing of the guideline in degrees and decimal degrees. The arrow indicates steering direction.</p>
	<p>Ground Speed: A user defined lightbar message indicating the vehicle speed in mile per hour (MPH). System unit is set to US.</p>
	<p>Ground Speed: A user defined lightbar message indicating the vehicle speed in kilometers per hour (KPH). System unit is set to Metric.</p>
	<p>Course on Ground (COG): A user defined lightbar message indicating the vehicles heading in degrees 0 to 359. The example to the left indicates the vehicle's course on the ground is due South (180 degrees).</p>
	<p>Area Applied: A user defined lightbar message indicating the current amount of area applied in acres. System unit is set to US.</p>
	<p>Area Applied: A user defined lightbar message indicating the current amount of area applied in hectares. System unit is set to Metric.</p>

LIGHTBAR INDEX

LIGHTBAR STATE	DESCRIPTION
	<p>Applied Area Detection: This message is displayed when the vehicle is within a previously applied area. Note the Red stop lights are illuminated. At this point an alarm will sound if the applied alarm setting was turned on in the user setup.</p>
	<p>Curved guidance information graphic. The four horizontal bars in the text display represent a perspective view of the swath ahead of the vehicle. The bars will skew left or right to represent the curved path ahead.</p>
	<p>Hazard Detection: The name of the hazard is displayed when the vehicle is approaching an existing hazard. Note the yellow stop lights are illuminated indicating the initial warning. Initial warning distance is set in system setup under Hazard Range.</p>
	<p>Hazard Detection: The name of the hazard is displayed when the vehicle is approaching an existing hazard. Note the red stop lights are illuminated indicating the final warning. Final warning distance is half the distance of the initial warning set in system setup under Hazard Range.</p>
	<p>Mapping Boundary: This message is displayed when the user is mapping the field boundary. The arrow symbol on the left indicates the field boundary is on the left side of the vehicle implement.</p>
	<p>Mapping Boundary: This message is displayed when the user is mapping the field boundary. The arrow symbol on the right indicates the field boundary is on the right side of the vehicle implement.</p>
	<p>System Warning: This message is displayed when there is a complete loss of DGPS (differential GPS corrections). Guidance calculations are stopped until differential corrections resume.</p>
	<p>System Warning: This message is displayed when there is a complete loss of GPS signal to the GPS receiver or SmartPad. Guidance calculations are stopped until GPS signal resumes.</p>
	<p>Lightbar Version Message: This message is displayed when the user runs the Lightbar Test. M4 indicates the Lightbar model and the 2.0 indicates the lightbar protocol version number. This number varies and is based on the lightbar version and model.</p>
	<p>Point Number: This is displayed only when using the Nav2point feature. Pt 3 indicates the number of the point the operator is navigating to.</p>
	<p>Distance to Point: This is displayed only when using the Nav2Point feature. The display indicates the distance to the point the user is navigating to.</p>